

► Vehicle Management and Monitoring Adapter

The Vehicle Management and Monitoring (VMM) Adapter provides an integrated solution for monitoring and reporting the geographic position, movement parameters and internal health of a vehicle.

The VMM Adapter incorporates a Global Positioning System (GPS) module, a Global System for Mobile Communication (GSM) module, autonomous data logging to onboard EEPROM, digital/analogue input as well as digital output functionality. An onboard rules engine allows easy and powerful user configuration. All VMM functions can be accessed using a powerful serial Application Program Interface (API). The adapter is available in the following industry standard compliant formfactors :

- PMC (IEEE Std 1386.1-2001)
- Conduction-Cooled PMC (CCPMC) (ANSI/VITA 20-2001)

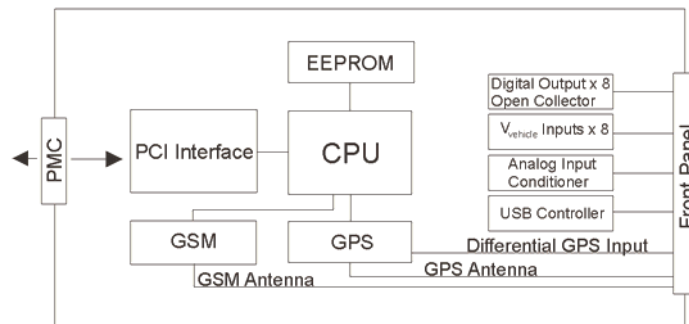

Features

- Full GPS functionality with differential GPS input
- GSM V2.5 (GPRS with built-in TCP/IP stack and SMS communication options)
- 128 Kbit of EEPROM for the logging user or onboard VMM data
- A powerful serial API providing access to all VMM functions
- An onboard rules engine that allows control functions to operate without interaction with the host. (for example, the unit may be programmed to report position via GPRS and activate an alarm when the GPS speed exceeds a preprogrammed setpoint)

This adapter can be controlled in the following ways :

- External command via serial port (external I/O)
- External command from host via PCI UART serial interface
- External command via GSM (GPRS or SMS)
- Internal, stand-alone operation using rule and function engine

Applications

- Vehicle tracking applications
- Position tracking applications
- Remote data logging using GPRS/SMS
- Remote control using GPRS/SMS
- Stand-alone data logging and control
- Easy to use GSM (GPRS/SMS) communication module



► **Vehicle Management and Monitoring Adapter**

Specifications	
Bus Interface	32-bit, 33/66 MHz Electrically : PCI Rev.2.3, 3,3 V and 5,0 V signalling
I/O Addresses	Automatically assigned to the slot by PCI Rev. 2.3 Plug-and-Play
EEPROM	1 K EEPROM for board PCI ID (Plug-and-Play) and configuration options 64 K EEPROM for configuration and user parameters, accessed via the embedded firmware
Interrupts	PCI INT A
I/O Interface	Various frontpanel (PMC and PC/104+) and rear connector (PMC and CCPMC Jn4) pin assignments
Serial Interface	RS-232 compatible asynchronous transfer with modem control signals
Serial Channels	1 x RS-232 channel with GPS option (includes RS-232 interface for DGPS)
GPS Receiver	L1 Frequency, C/A Code, 12 Channel
GPS Data Format	Serial API
GPS Update Rate	1 Hz
GPS Operating Limits	Altitude < 18 000 m, Velocity < 515 m/s, if GPS option is fitted COCOM (Coordinate Committee on Export Controls) restrictions apply
GSM Module	GPRS and SMS
GSM Data Format	Serial API
EEPROM	128 Kbit for data logging or general storage
EEPROM Data Format	Serial API
Analog Inputs	2
Digital Inputs	8
Digital Outputs	8
Analog / Digital I/O	Serial API
Data Rate	4 800 bit/s to 38,4 kbit (9 600 bit/s standard)
CAN Interface	Two Controller Area Network (CAN) interfaces provided, conforming to CAN Specification Version 2.0 Part A and B, with a maximum bit rate of 1 MHz
Power	5,0 V @ 0,60 A (PCI / ISA supply) 6,0 V to 60,0 V @ 0,45 A (external supply)
Software Drivers	The EMAC uses an industry standard UART to the user. As such, no specific driver is required for most Operating Systems. VxWorks source code to locate the device in PCI spates and obtain a pointer to the UART is supplied as an example



▶ Vehicle Management and Monitoring Adapter

Characteristics		
Formfactor	Dimensions	Mass
PMC (IEEE Std 1386.1-2001)	149,00 mm x 74,00 mm, conforming to CMC envelope	95 ± 10 g
CCPMC (ANSI/VITA 20-2001)	143,65 mm x 74,00 mm, conforming to VITA 20 envelope	70 ± 10 g
PC/104-Plus (PC/104-Plus v2.0)	95,9 mm x 90,2 mm x 23,80 mm	95 ± 10 g

Reliability			
MTBF	Figures according to MIL-HDBK-217F, Parts Stress Method (Predicted)		
	Ground, Mobile Naval, Sheltered Airborne, Inhabited Cargo	T _a = 45 C T _a = 40 C T _a = 55 C	20 000 hours 35 000 hours 25 000 hours

Environmental Specifications			
	Commercial Grade	Industrial Grade	Ruggedised/Conduction-Cooled Grade
Temperature - Operating - Storage	0 C to +55 C -40 C to +85 C	-15 C to +75 C -40 C to +85 C	-40 C to + 85 C -55 C to +125 C
Humidity	0% - 90%	0% - 95%	0% - 95%
Shock	N/A	30 g peak for 11 ms	40 g peak for 11 ms
Vibration - Sine - Random	2 g (peak) 10 Hz to 100 Hz 0,04 g ² /Hz at 15 Hz to 2 kHz	10 g (peak) 5 Hz to 2 kHz 0,1 g ² /Hz at 15 Hz to 2 kHz	10 g (peak) 5 Hz to 2 kHz 0,1 g ² /Hz at 15 Hz to 2 kHz

Part Selector			
Part Designation	Formfactor	Grade	I/O Options
CCII/VMM/PMC/FP/COM	PMC	Commercial	Frontpanel or Backplane I/O
CCII/VMM/PMC/FP/IND	PMC	Industrial	Frontpanel or Backplane I/O
CCII/VMM/PMC/FP/RGD	PMC	Ruggedised	Frontpanel or Backplane I/O
CCII/VMM/PMC/BP/CC	CCPMC	Conduction-Cooled	Backplane I/O