

## ▶ 6U VME64x Airborne Computer

The 6U VME64x Airborne Computer is a single slot, 64-bit PowerPC-based computing system with a wide variety of inputs and outputs as well as multi-function interfaces. The Airborne Computer host board uses a quad-core NXP T2080 processor and provides three Gigabit Ethernet channels, two serial UARTs, NAND and NOR flash memory. The Airborne Computer may be upgraded to include the quad-core NXP T4080 processor or the 12-core NXP T4240 processor.

Two companion XMC adapters provide multiple I/O options. As standard, the first companion XMC adapter provides two dual-redundant MIL-STD-1553B channels, nine ARINC 429 channels (three input and six output), four RS-232/422/485 channels and 2 MByte of Parallel Non-Volatile Random Access Memory (NVRAM). The second companion XMC adapter provides the modern Xilinx Artix-7 series FPGA which is configured with a dual-channel high-speed 160 MSps Analog-to-Digital converter, eight RS-422/485 channels and 32 Low Voltage Transistor-Transistor Logic (LVTTTL) I/O signals routed to the backplane connector, as well as eight SMD LED signals from the User FPGA. This FPGA is user-programmable.

The 6U VME64x Airborne Computer is compatible with any 6U VME64x backplane and complies with VITA 1.1-1997 R2003 with the exception of the reduced depth.

The 6U VME64x Airborne Computer has multiple memory and CPU speed configurations and is available in commercial grade air-cooled, industrial grade air-cooled and ruggedised grade conduction-cooled versions.

### Architecture

The Airborne Computer consists of a VME64x host board, having a PowerPC T2080 processor and two PMC/XMC sites, with a PCIe switch linking the XMC sites to the T2080 processor.

Two companion XMC adapters are used to provide access to multiple I/O interfaces and options, as well as the Xilinx Artix-7 FPGA. The PMC I/O signals are connected to the VME64x P2 and P0 connectors on the backplane.

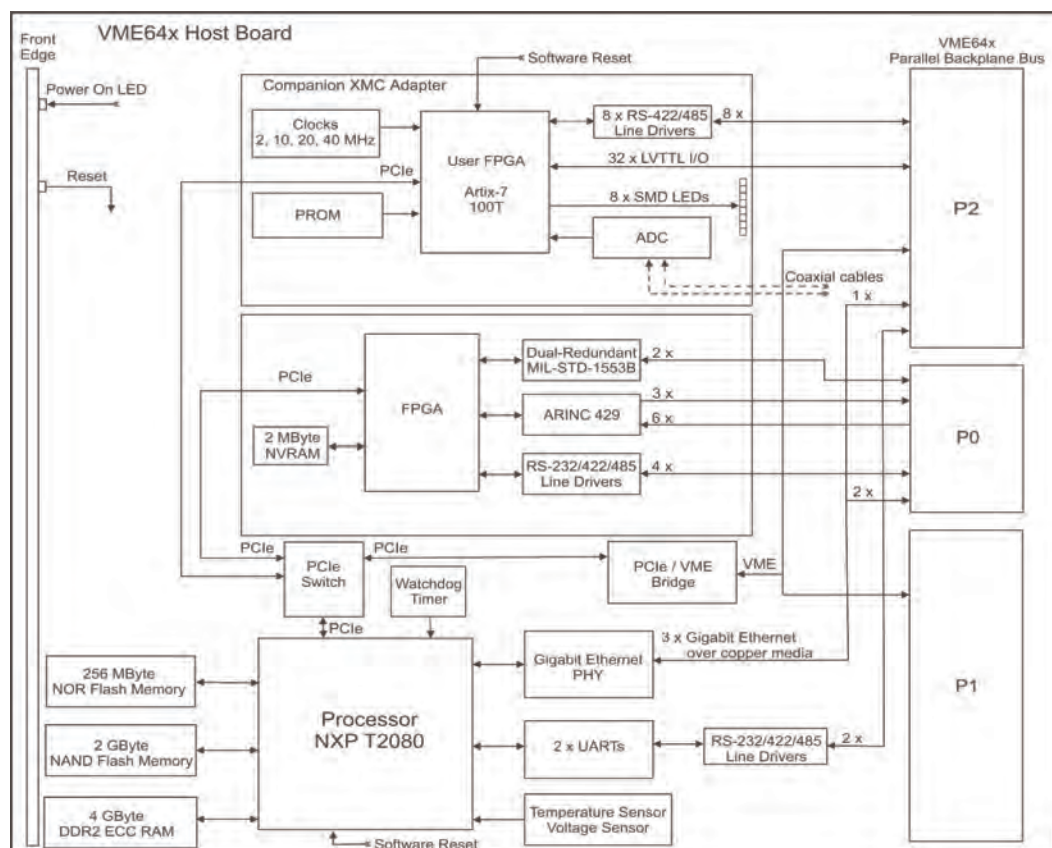

6U VME64x Airborne Computer Block Diagram



## ► 6U VME64x Airborne Computer

### Features

- NXP T2080 processor with four dual-threaded cores
- 64-bit parallel backplane bus
- 4 GByte of DDR2 ECC SDRAM
- 256 MByte of NOR Flash Memory
- 2 GByte of NAND Flash Memory
- 2 MByte of Parallel NVRAM
- 6 x RS-232/422/485 channels routed to backplane connector
- 3 x Gigabit Ethernet channels over copper media to backplane connector
- I²C Temperature Sensor and Voltage Sensor
- Watchdog Timer and four 32-bit Timers
- Xilinx Artix-7 100T Series FPGA (User FPGA)
- 8 x duplex RS-422/485 channels (routed to User FPGA)
- 2 MHz, 10 MHz, 20 MHz and 40 MHz Clocks (routed to User FPGA)
- Dual-channel 14-bit 160 MSps ADC module (routed to User FPGA)
- 3 x Tx and 6 x Rx ARINC 429 channels
- 2 x dual-redundant MIL-STD-1553B channels (Bus Controller and Remote Terminal)
- 20 x Test Signals from User FPGA
- 32 x Low Voltage TTL (LVTTTL) I/O signals
- 8 x SMD LED Signals from User FPGA
- Software Reset for Processor and User FPGA
- Reset Button and Power On LED
- Rear Transition Module (RTM) with 3 x Gigabit Ethernet connectors and 2 x RS-232 connectors

Specifications	
<b>Processor</b>	NXP T2080 processor with four dual-threaded e6500 cores at up to 1,8 GHz NXP T4080 processor with four dual-threaded e6500 cores at up to 1,8 GHz (optional) NXP T4240 processor with twelve dual-threaded e6500 cores at up to 1,8 GHz (optional)
<b>Cache</b>	2 MByte of shared L2 Cache
<b>RAM Memory</b>	4 GByte of DDR2 ECC SDRAM Memory in two channels
<b>Flash Memory</b>	256 MByte of NOR Flash Memory 2 GByte of NAND Flash Memory
<b>Non-Volatile Memory</b>	2 MByte of Parallel NVRAM (on companion XMC adapter)
<b>Serial I/O</b>	6 x UART channels : 2 x RS-232/422/485 channels with software flow control, routed to backplane connector 4 x RS-232/422/485 channels, routed to backplane connector
<b>Gigabit Ethernet LAN</b>	3 x Gigabit Ethernet channels over copper media, routed to backplane connector
<b>Temperature and Voltage Sensor</b>	I²C Temperature Sensor and Voltage Sensor Accuracy : +/-3% over range -40 C to +85 C
<b>Timers</b>	Watchdog Timer and four 32-bit Timers (Watchdog timeout of 10 seconds)
<b>ADC</b>	Two independent 14-bit ADC channels with configurable sampling rate up to 160 MSps per channel continuous capture : - Signal Bandwidth : 3 MHz - Signal Amplitude : 2,2 V peak-peak - Sampling Rate : up to 160 MSps - SINAD : 72 dB - SFDR : 86 dB - ADC Resolution : 14 bits - Coupling : DC - Line Termination : 50 Ohm Input via coaxial cables



Preliminary

Force Multiplication through Information Technology®



► **6U VME64x Airborne Computer**

Specifications (continued)	
<b>Formfactor (Size)</b>	6U VME64x (VITA 1.1-1997 R2003) with modified depth
<b>Backplane Connectors</b>	IEC 61076-4-113 160-pin connector x 2 IEC 61076-4-101 95-pin connector x 1
<b>Software Resets</b>	Software Reset for Processor Software Reset for User FPGA
<b>MIL-STD-1553B</b>	2 x dual-redundant channels, routed to backplane connector, Bus Controller and Remote Terminal
<b>ARINC 429</b>	3 x transmit channels, routed to backplane connector 6 x receive channels, routed to backplane connector
<b>User FPGA</b>	Xilinx Artix-7 100T Series with up to 100K logic cells
<b>RS-422/485</b>	8 x RS-422/485 channels, routed from User FPGA to backplane connector (Tx+/Tx- and Rx+/Rx-)
<b>LVTTTL I/O</b>	32 x Low Voltage TTL interfaces routed to backplane connector from User FPGA for external user interface
<b>PROM</b>	Platform Flash Memory for configuration of User FPGA Programmable through JTAG
<b>Clocks</b>	2 MHz, 10 MHz, 20 MHz and 40 MHz routed to User FPGA
<b>Test Signals</b>	20 x Test Signals from User FPGA routed to Header on companion XMC adapter 8 x SMD LED Signals from User FPGA on companion XMC adapter
<b>Test Interface</b>	JTAG Header

Characteristics			
	Dimensions	Cooling	Weight
<b>Physical</b>	233,35 mm high 160,0 mm deep including VME connectors ≈16 mm wide	Air	780 g +/- 50 g
	233,35 mm high less than 160,0 mm deep including VME connectors ≈16 mm wide	Conduction	770 g +/- 50 g
<b>Maximum Power Consumption</b>	T2080 Quad-Core 1,8 GHz T4080 Quad-Core 1,8 GHz T4240 12-Core 1,8 GHz	55 Watt 60 Watt 70 Watt	
<b>Software</b>	VxWorks Operating System and software drivers Support for Gentoo Linux		

6U VME64x Airborne Computer  
System-Level



► **6U VME64x Airborne Computer**

Reliability			
<b>MTBF</b>	Figures according to MIL-HDBK-217F, Parts Stress Method		
	Commercial Grade	Ground Benign, Controlled, 25 C	105 000 hours
	Industrial Grade	Ground, Mobile, 45 C	13 000 hours
		Naval, Sheltered, 40 C	22 000 hours
		Airborne, Inhabited Cargo, 55 C	11 000 hours
		Airborne, Uninhabited Cargo, 70 C	7 000 hours
		Airborne, Rotary Wing, 55 C	8 000 hours
		Airborne, Inhabited Fighter, 55 C	8 000 hours
	Airborne, Uninhabited Fighter, 70 C	4 000 hours	
	Ruggedised Grade	Ground, Mobile, 45 C	14 000 hours
Naval, Sheltered, 40 C		24 000 hours	
Airborne, Inhabited Cargo, 55 C		12 000 hours	
Airborne, Uninhabited Cargo, 70 C		7 000 hours	
Airborne, Rotary Wing, 55 C		9 000 hours	
Airborne, Inhabited Fighter, 55 C		10 000 hours	
Airborne, Uninhabited Fighter, 70 C	5 000 hours		

Environmental Specifications			
	Commercial Grade	Industrial Grade	Ruggedised Grade
<b>Temperature</b> - Operating - Storage	0 C to +55 C -40 C to +85 C	-40 C to +70 C -55 C to +85 C	-40 C to +85 C -55 C to +105 C
<b>Humidity</b>	0% to 90%	0% to 95%	0% to 95%
<b>Shock</b>	20 g peak for 11 ms	30 g peak for 11 ms	40 g peak for 11 ms
<b>Vibration</b> - Sine - Random	2 g (peak) 10 Hz to 100 Hz 0,002 g²/Hz 5 Hz to 2 kHz	5 g (peak) 5 Hz to 2 kHz 0,04 g²/Hz 5 Hz to 2 kHz	10 g (peak) 5 Hz to 2 kHz 0,1 g²/Hz 5 Hz to 2 kHz

Part Selector		
Part Designation	Cooling	Grade
CCII/AC/6UVME64x/003/COM	Air	Commercial
CCII/AC/6UVME64x/003/IND	Air	Industrial
CCII/AC/6UVME64x/003/CC	Conduction	Ruggedised

6U VME64x Airborne Computer  
System-Level